

Large Flange Head Nutsert

Body Type: Round Closed

Outside Body: Smooth

Thread Type: Metric - Coarse

Body Material: Stainless Steel

Class Grade: A2-70 G304

Finish: Stainless Steel A2-70 G304

Corrosion Protection Level: Excellent

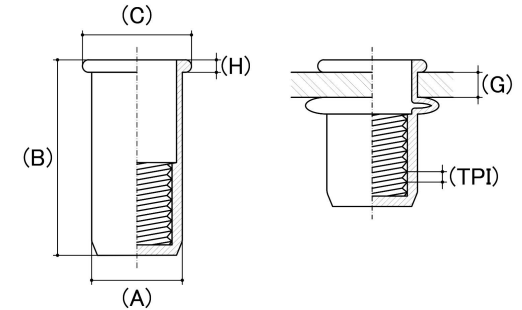

*CAD drawings shown for graphic representation only.**

| Size | Thread Pitch (mm) | Thread Type | Material Grip Range (G) (mm) | | Overall Nut Height (B) (mm) | Head Diameter (C) (mm) | Nut Width (A) (mm) | Flange Thickness (H) (mm) | Recommended Hole Size (mm) | Pull Out (KN) | Push Out (KN) | Torque To Turn (NM) | | sku (qfind) |
|------|-------------------|-------------|------------------------------|------|-----------------------------|------------------------|--------------------|---------------------------|----------------------------|---------------|---------------|---------------------|-----|-------------|
| | | | Min | Max | Nom | Nom | Nom | Nom | Nom | Nom | Nom | Nom | Min | |
| M4 | 0.70 | Coarse | 0.50 | 2.50 | 16.00 | 7.00 | 5.90 | 1.00 | 6.00 | 7 | 4 | 4.9 | - | 43LFCES4SM |
| M5 | 0.80 | Coarse | 0.50 | 3.00 | 18.00 | 8.00 | 6.90 | 1.00 | 7.00 | 12 | 5 | 9.8 | - | 43LFCES5SM |
| M6 | 1.00 | Coarse | 0.50 | 3.00 | 21.00 | 10.00 | 8.90 | 1.50 | 9.00 | 20 | 8 | 14.7 | - | 43LFCES6SM |
| M8 | 1.25 | Coarse | 0.50 | 3.00 | 23.50 | 12.00 | 10.90 | 1.50 | 11.00 | 32 | 10 | 44.1 | - | 43LFCES8SM |
| M10 | 1.50 | Coarse | 1.00 | 3.50 | 26.50 | 14.20 | 12.90 | 2.00 | 13.00 | 44 | 13 | - | - | 43LFCES10SM |

Disclaimer:

Dimensional data and technical information was obtained from publically available sources and not acquired through standard agencies. It has been completed and compiled for reference purposes only; where discrepancies are found they are subject to change without notice. Bolt & Nut Australia makes no warranties or representations regarding the accuracy and validity of the compiled information and data. Contact the relevant standard authorities for accurate and detailed information.

* CAD drawings may not reflect diameter, thread length or overall length.

© Bolt & Nut Australia Pty Ltd. All rights reserved.

Version: 18 Mar 2024